

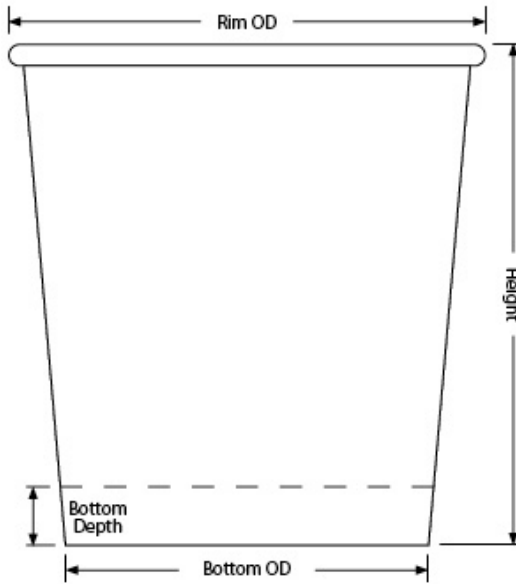

H9T2 12oz Container (T2)

12oz T2 Recycled Paper HOT Container



Capacity: 12.75oz / 377.00ml

Material: 18pt Recycled Paper, Poly 1-side, 35% Sustana
Envirolife Post-Consumer Recycled Fiber, FSC SFI
PEFC Certified

Minimum: 2,000 pieces

Height: 3.687" \pm .015

Rim Height: 0.150" \pm .010

Rim OD: 3.515" \pm .010

Bottom OD: 2.665" \pm .010

Bottom Depth: 0.414" \pm .010

Shipping: FOB NV Made in the USA

12oz Container (T2) available in [Cold Paper](#) [Hot Paper](#)
[Plastic-Free](#) [Clear Plastic](#) [White Plastic](#)

H9T2 Standard Case Pack Configuration

Box Dimensions: 18.10"x14.63"x23.38"

Box Volume: 3.58 Cubic Feet

Box Weight: 36 lbs

Box Content: 1,000 Pieces

Pallet Dimensions: 40.00"x48.00"x99"

Pallet Weight: 909 lbs

Pallet Content: 24,000 Pieces / 24 Boxes

SEE LID OPTIONS ON LAST PAGE

Pallet for H9T2

12oz T2 Recycled Paper HOT Container

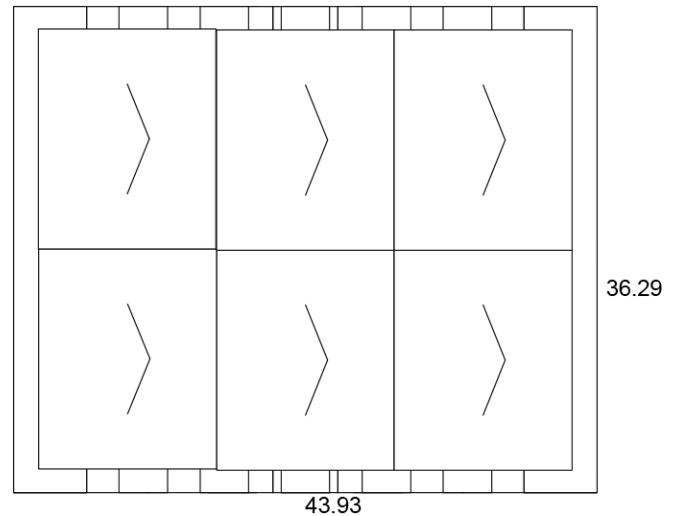
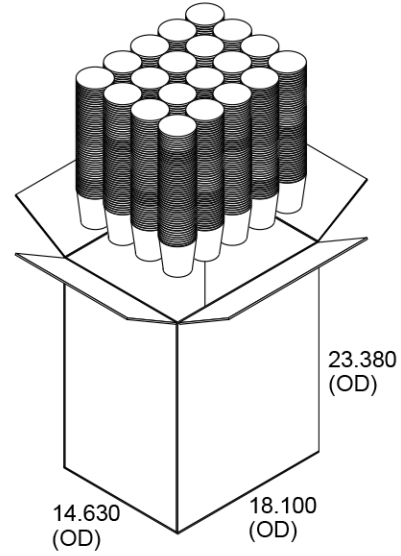
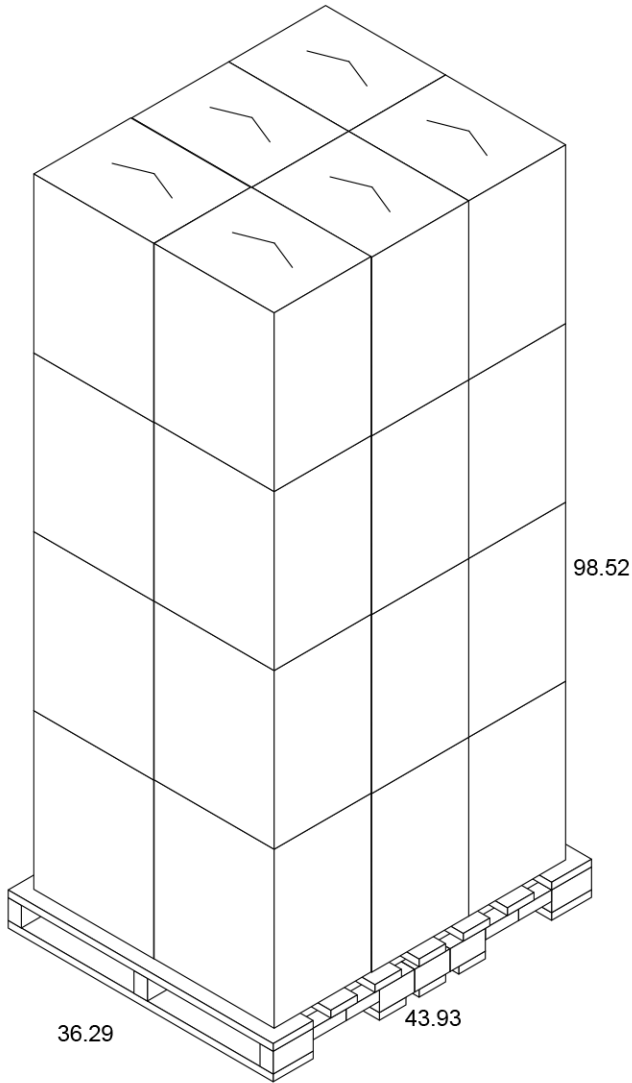

Lid Options for H9T2

12oz T2 Recycled Paper HOT Container



P2 Printed Snap-Fit Paper

- Hi-Definition, Full Color
- Customizable
- Seamlessly registered text
- Uninterrupted text
- Three week leadtime
- Case: 500 - 10 lbs



Clear Single-Use Lid

- Clear, thermo-formed
- With & without straw slot
- Case: 1,000 - 8 lbs



Clear High Dome Lid

- Clear, thermo-formed
- With top opening
- Case: 1,000 - 10 lbs



Cappuccino Lid

- White/Black, thermo-formed
- Vented lid
- Case: 1,000 - 8 lbs