

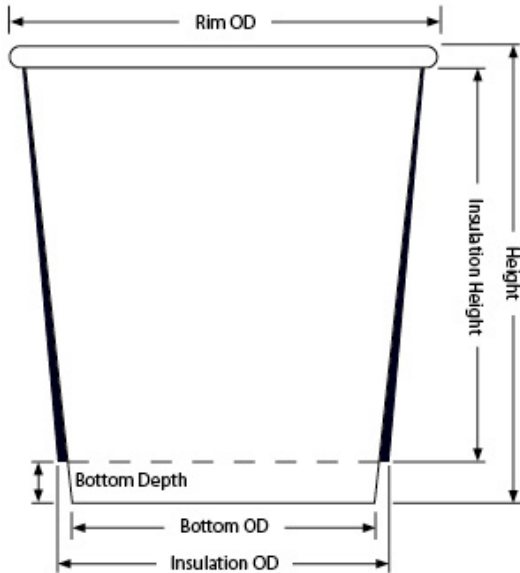

X2D9 9oz Drink Cup (D9)

9oz Double Wall Recycled Paper Cup



Capacity: 8.80oz / 260.00ml

Material: 16.5pt Recycled Paper, Poly 1-side, 35% Sustana
EnviroLife Post-Consumer Recycled Fiber, FSC SFI
PEFC Certified

Minimum: 1,000 pieces

Height: 3.356" \pm .015

Rim Height: 0.150" \pm .010

Rim OD: 3.143" \pm .010

Bottom OD: 2.215" \pm .010

Bottom Depth: 0.301" \pm .010

Shipping: FOB NV Made in the USA

9oz Drink Cup (D9) available in [Double Wall](#) [Double Wall](#)

X2D9 Standard Case Pack Configuration

Box Dimensions: 22.00"x13.06"x15.33"

Box Volume: 2.55 Cubic Feet

Box Weight: 19 lbs

Box Content: 500 Pieces

Pallet Dimensions: 40.00"x48.60"x97"

Pallet Weight: 729 lbs

Pallet Content: 18,000 Pieces / 36 Boxes

SEE LID OPTIONS ON LAST PAGE

Pallet for X2D9 (Gloss), XHD9 (Matte)

9oz Double Wall Recycled Paper Cup

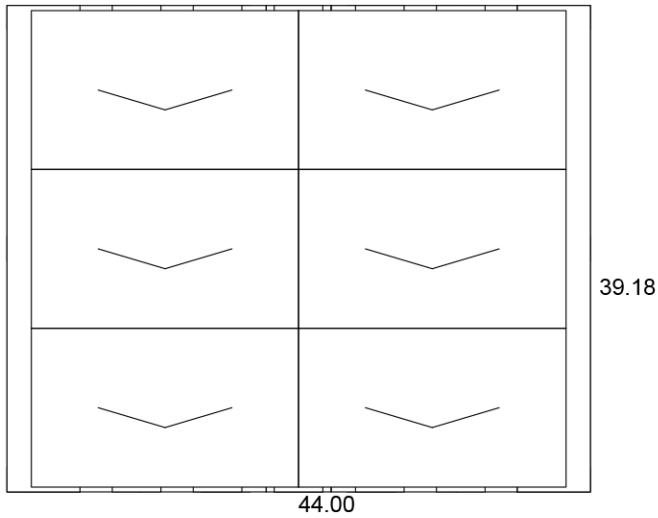
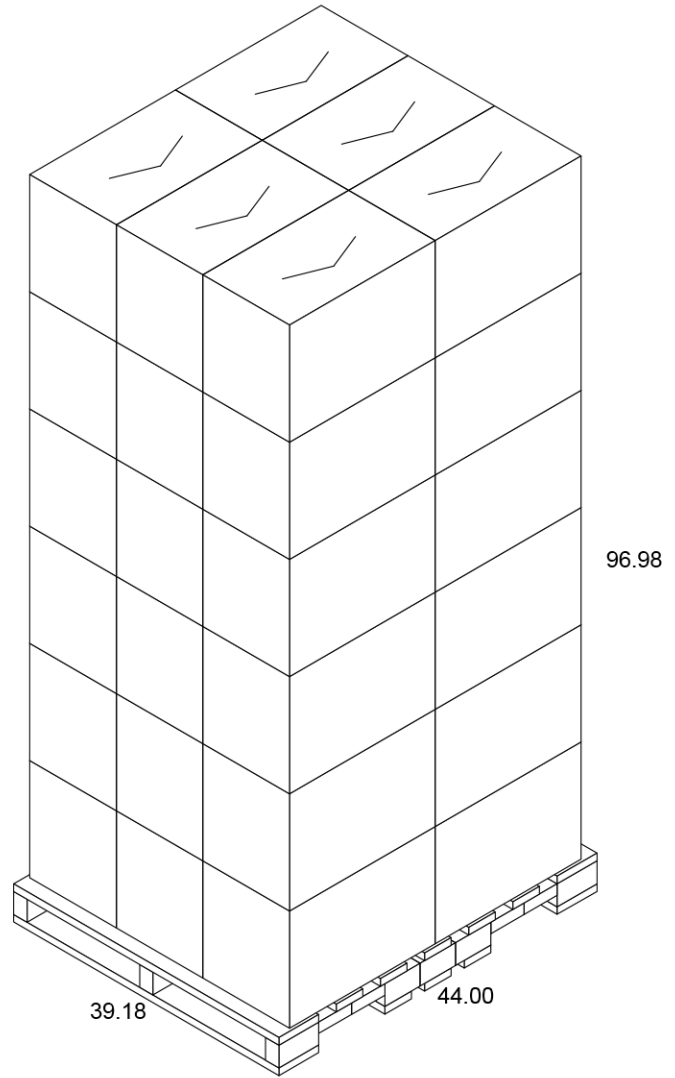
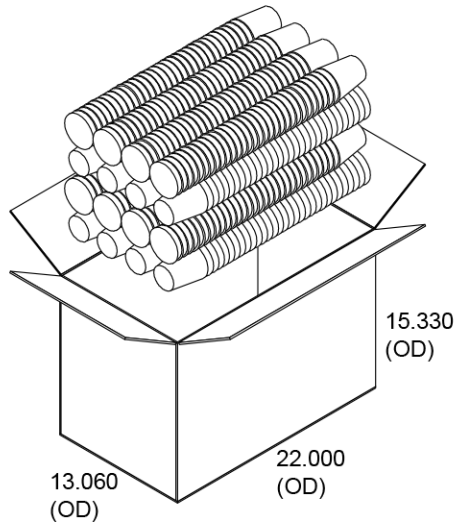



Lid Options for X2D9 (Gloss), XHD9 (Matte) 9oz Double Wall Recycled Paper Cup



Clear Single-Use Lid

- Clear, thermo-formed
- With & without straw slot
- Case: 1,000 - 8 lbs



Cappuccino Lid

- White/Black, thermo-formed
- Vented lid
- Case: 1,000 - 8 lbs